

MODULE 2: OSCILLATORS AND COMPARATORS

Oscillator Principles

An oscillator is a type of feedback amplifier. In which part of the output is feedback to the input via a feedback circuit. If the signal feedback is of proper magnitude and phase, the circuit produces alternating currents or voltages. To visualise the requirements of an oscillator, consider the block diagram of fig. 7

However, here the input voltage is zero ($V_{in} = 0$). Also, the feedback is positive because most oscillators use positive feedback. Finally, the closed loop gain of the amplifier is denoted by A_v rather than A_F .

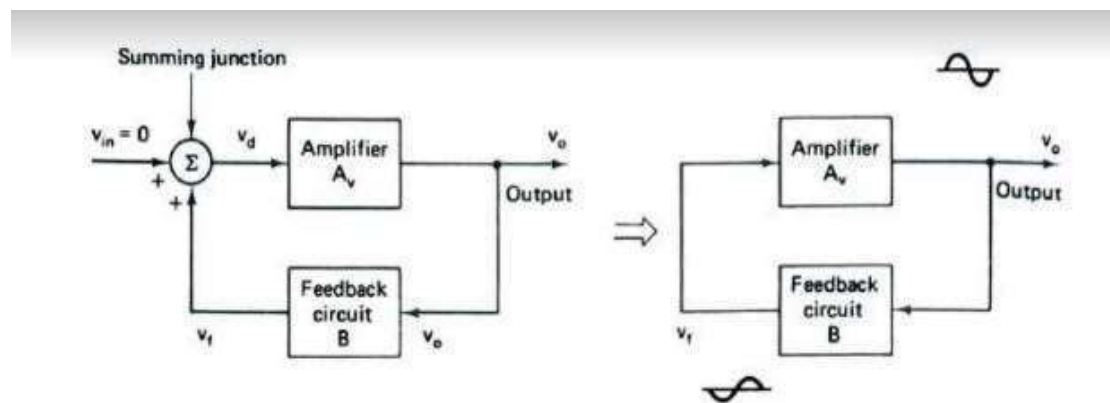

FIGURE 7-17 Oscillator block diagram.

In the block diagram of figure 7

$$V_d = V_f + V_{in}$$

$$V_o = A_v V_d$$

$$V_f = B V_o$$

Using these relationships, the following equation is obtained:

$$\frac{V_o}{V_{in}} = \frac{A_v}{1 - A_v B}$$

However, $v_{in} = 0$ and $v_o \neq 0$ implies that

$$A_v B = 1 \quad (1)$$

Expressed in polar form,

Equation 2 gives the two requirements for oscillation

$$A_v B = 1/0^\circ \text{ or } 360^\circ \text{ (2)}$$

1. The magnitude of the loop gain $A_v B$ must be atleast 1
2. The total phase shift of the loop gain $A_v B$ must be equal to 0° or 360°

For instance in figure 7, if the amplifier causes a phase shift of 180° , the feedback circuit must provide an additional phase shift of 180° , so that phase shift around the loop is 360° .

The Waveforms shown in fig 7 are sinusoidal and are used to illustrate the circuit's action. The type of waveform generated by an oscillator depends on the component and hence may be sinusoidal, square or triangular.

The frequency of the oscillation is determined by the components in the feedback circuit.

Oscillator Types

Types of components used	Frequency of Oscillation	Types of waveform generated
RC oscillator	Audio frequency	Sinusoidal
LC oscillator	Radio Frequency	Square Wave
Crystal Oscillators		Triangular Wave Sawtooth wave etc

Frequency Stability

The ability of the oscillator circuit to oscillate at one exact frequency is called frequency stability. Although a number of factors may cause changes in oscillator frequency, the primary factors are temperature changes and changes in the dc power supply.

Temperature and power supply changes cause variations in the op=amp's gain, in junction capacitances and resistances of the transistors in an op-amp, and in external circuit components. In most cases these variations can be kept small by careful design, by using regulated power supplies, and by temperature control.

Another important factor that determines frequency stability is the figure of merit Q of the circuit. The higher the Q, the greater the stability. For this reason, crystal oscillators are far more stable than RC or LC oscillators, especially at higher frequencies.

Phase Shift Oscillator

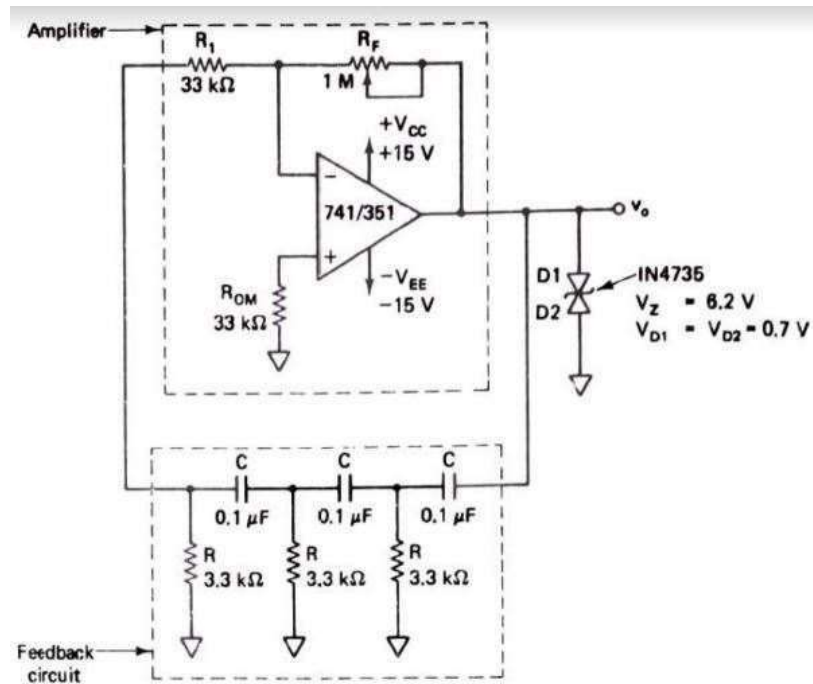

Fig 7.18 shows a phase shift oscillator, which consists of an op-amp as the amplifying stage and three RC cascaded networks as the feedback circuit. The feedback circuit provides feedback voltage from the output back to the input of the amplifier.

The op-amp is used in the inverting mode; therefore, any signal that appears at the inverting terminal is shifted by 180° at the output. An additional 180° phase shift required for oscillation is provided by the cascaded RC networks. Thus, the total phase shift around the loop is 360° .

At some specific frequency when the phase shift of the cascaded RC networks is exactly 180° and the gain of the amplifier is sufficiently large, the circuit will oscillate at that frequency.

This frequency is called frequency of oscillation, f_o and is given by

$$f_o = \frac{1}{2\pi\sqrt{6}RC} = \frac{0.065}{RC} \quad (\text{equation 1})$$

At this frequency, the gain A_v must be at least 29. That is,

$$\left| \frac{R_F}{R_1} \right| = 29$$

Or

$$R_F = 29R_1 \quad (\text{Equation 2})$$

Thus the circuit will produce a sinusoidal waveform of frequency f_o if the gain is 29 and the circuit will produce a sinusoidal waveform of frequency f_o if the gain is 29 and the total phase shift around the circuit is exactly 360° . For a desired frequency of oscillation, choose a capacitor C, and then calculate the value of R from equation 2.

A desired current amplitude, however can be obtained with back to back zeners connected at the output terminal

Design the phase shift oscillator of fig 7.18 so that $f_o = 200\text{Hz}$ (Important)

Or

Design and explain the working of RC phase shift oscillator for $f_o = 200\text{Hz}$

(solve the problem first and then explain phase shift oscillator and then draw diagram)

Let $C = 0.1 \mu\text{F}$. Then, from the equation

$$f_o = \frac{1}{2\pi\sqrt{6}RC} = \frac{0.065}{RC}$$

$$R = \frac{0.065}{(200)(10^{-7})} = 3.25\text{k}\Omega$$

(Use $R = 3\text{k}\Omega$)

To prevent the loading of the amplifier because of RC networks, it is necessary that $R_1 \geq 10R$.

Therefore let $R_1 = 10R = 33\text{k}\Omega$. Then from $R_F = 29R_1$

$$R_F = 29(33\text{k}\Omega) = 957\text{k}\Omega$$

(Use $R_F = 1\text{-M}\Omega$ potentiometer)

When choosing an op-amp, type 741 can be used at lower frequencies ($<1\text{kHz}$)

Wien Bridge Oscillator

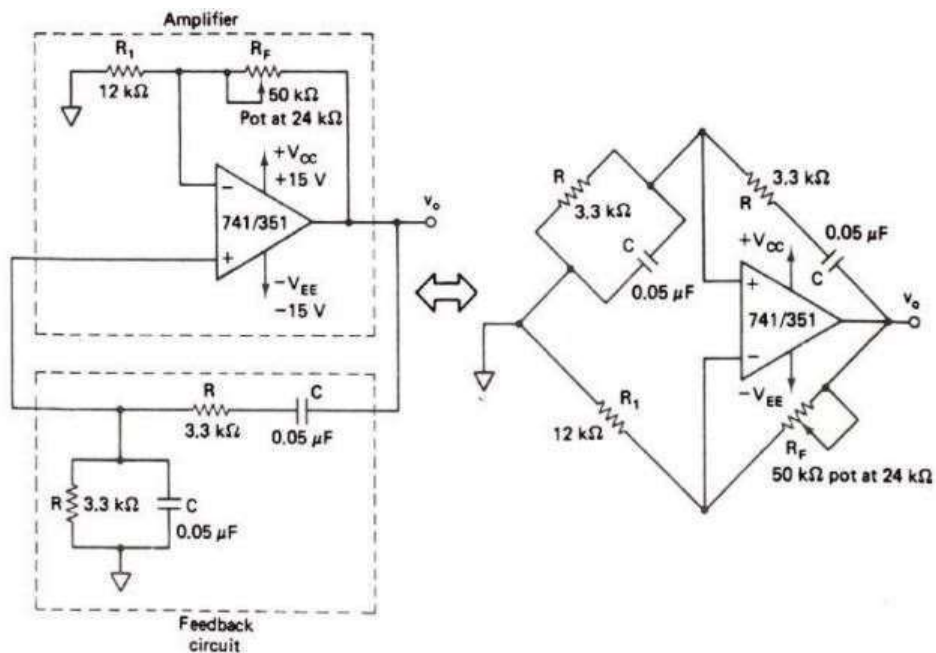

FIGURE 7-19 Wien bridge oscillator.

Because of its simplicity and stability, one of the most commonly used audio frequency oscillators is the Wien Bridge. Fig shows the Wien Bridge oscillator in which the Wien bridge circuit is connected between the amplifier input terminals and the output terminal. The bridge has a series RC network in one arm and a parallel RC network in the adjoining arm. In the remaining two arms of the bridge, resistors R_1 and R_F are connected

The phase angle criterion for oscillation is that the total phase shift around the circuit must be 0° . This condition occurs only when the bridge is balanced, that is, at resonance. The frequency of oscillation f_0 is exactly the resonant frequency of the balanced Wien bridge and is given by

$$F_o = \frac{1}{2\pi RC} = \frac{0.159}{RC} \text{ (Equation 1)}$$

Assuming that the resistors are equal in value, and the capacitors are equal in value in the reactive leg of the Wien bridge. At this frequency the gain required for sustained oscillation is given by

$$A_v = \frac{1}{B} = 3$$

That is,

$$1 + \frac{R_F}{R_1} = 3$$

Or

$$R_F = 2R_1 \text{ (Equation 2)}$$

Img

The Wien Bridge oscillator is designed using equation 1 and 2 as illustrated in fig

Design the Wien bridge oscillator of fig 7.19 so that $f_0 = 965$ Hz

(same procedure as phase shift)

Let $C = 0.05\mu F$. therefore from equation

$$R = \frac{\frac{0.159}{RC}}{(5)(10^{-8})(965)} = 3.3k\Omega$$

Now, let $R_1 = 12 k\Omega$. Then from equation

Comparator

$$R_f = \frac{R_1}{2} \text{ (potentiometer)}$$

R
F
=
(
2
)
(
1
2
k
 Ω
)
=
2
4
k
 Ω
(
U
s
e
R
F
=
5
0
k
 Ω
p
o

A **comparator** is an electronic circuit, which compares the two inputs that are applied to it and produces an output. The output value of the comparator indicates which of the inputs is greater or lesser.

Basic Comparator

Inverting Comparator

An **inverting comparator** is an op-amp based comparator for which a reference voltage is applied to its non-inverting terminal and the input voltage is applied to its inverting terminal. This comparator is called as **inverting** comparator because the input voltage, which has to be compared is applied to the inverting terminal of op-amp.

The **circuit diagram** of an inverting comparator is shown in the following figure.

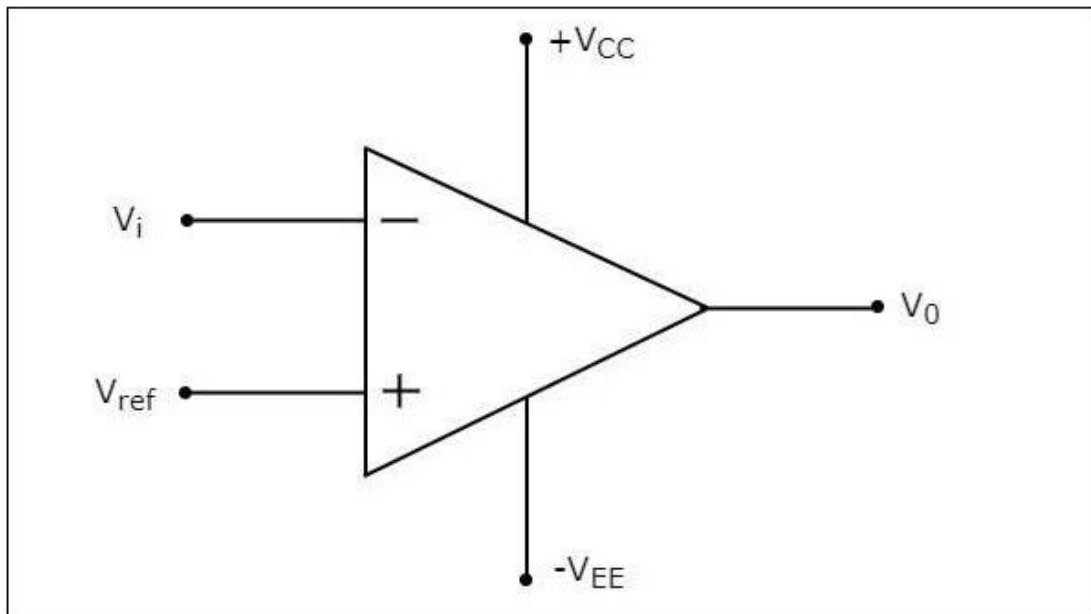

The **operation** of an inverting comparator is very simple. It produces one of the two values, $+V_{sat}$ and $-V_{sat}$ at the output based on the values of its input voltage V_i and the reference voltage V_{ref} .

- The output value of an inverting comparator will be $-V_{sat}$, for which the input V_i voltage is greater than the reference voltage V_{ref} .
- The output value of an inverting comparator will be $+V_{sat}$, for which the input V_i is less than the reference voltage V_{ref} .

The following figure shows the **input and output waveforms** of an inverting comparator, when the reference voltage is zero volts.

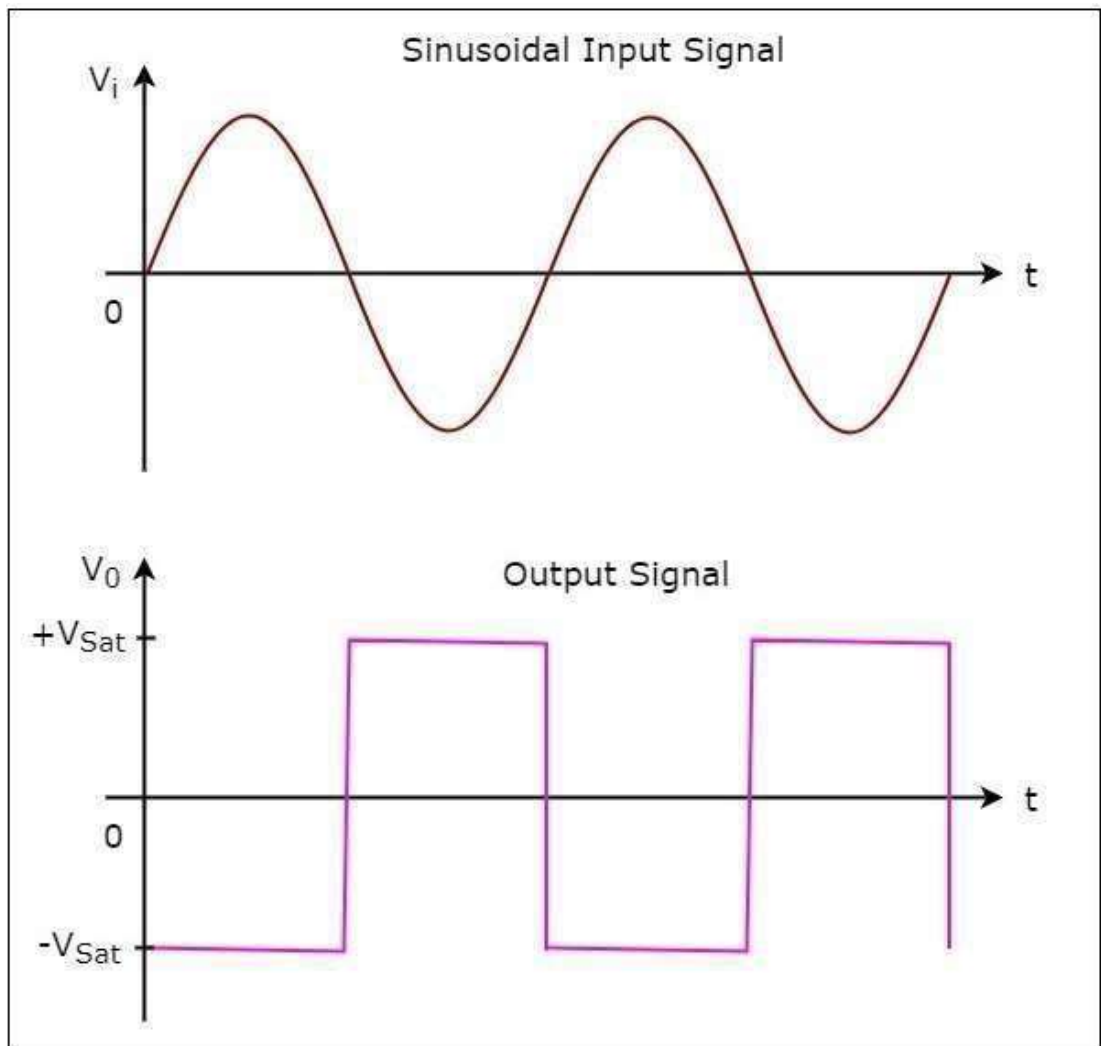

- In the figure shown above, we can observe that the output transitions either from $-V_{sat}$ to $+V_{sat}$ or from $+V_{sat}$ to $-V_{sat}$ whenever the sinusoidal input signal is crossing zero volts. In other words, output changes its value when the input is crossing zero volts. Hence, the above circuit is also called as **inverting zero crossing detector**.

Non-Inverting Comparator

A non-inverting comparator is an op-amp based comparator for which a reference voltage is applied to its inverting terminal and the input voltage is applied to its non-inverting terminal. This op-amp based comparator is called as **non-inverting** comparator because the input voltage, which has to be compared is applied to the non-inverting terminal of the op-amp.

The **circuit diagram** of a non-inverting comparator is shown in the following figure

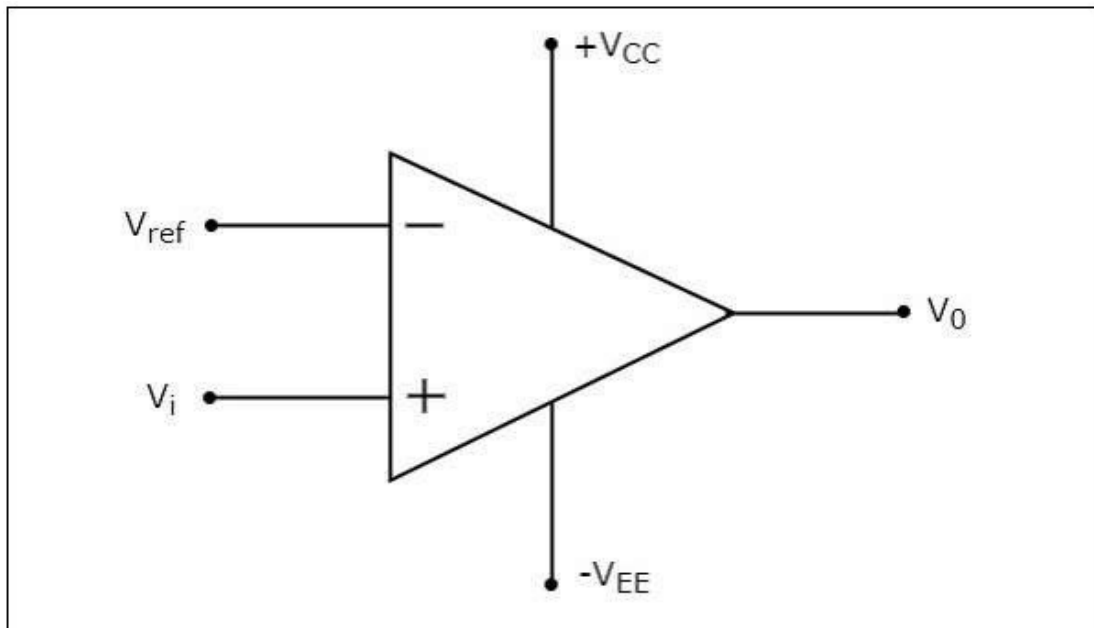

The **operation** of a non-inverting comparator is very simple. It produces one of the two values, $+V_{sat}$ and $-V_{sat}$ at the output based on the values of input voltage V_i and the reference voltage $+V_{ref}$.

- The output value of a non-inverting comparator will be $+V_{sat}$ for which the input voltage V_i is greater than the reference voltage $+V_{ref}$.
- The output value of a non-inverting comparator will be $-V_{sat}$, for which the input voltage V_i is less than the reference voltage $+V_{ref}$.

The following figure shows the **input and output waveforms** of a non-inverting comparator, when the reference voltage is zero volts.

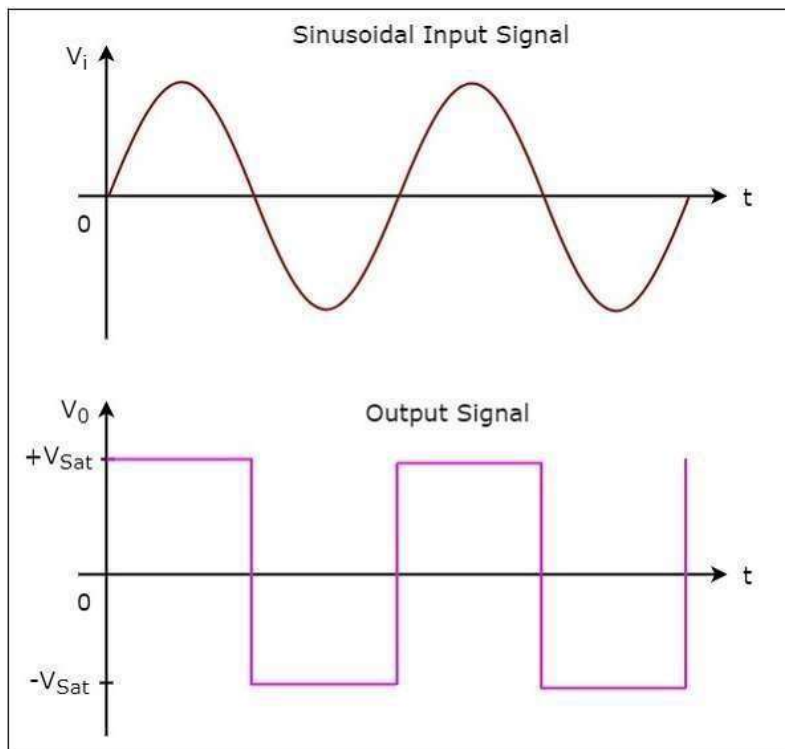

- From the figure shown above, we can observe that the output transitions either from $+V_{\text{sat}}$ to $-V_{\text{sat}}$ or from $-V_{\text{sat}}$ to $+V_{\text{sat}}$ whenever the sinusoidal input signal crosses zero volts. That means, the output changes its value when the input is crossing zero volts. Hence, the above circuit is also called as **non-inverting zero crossing detector**.

Zero Crossing Detector

An immediate application of the comparator is the zero-crossing detector or sine wave-to-square wave converter. The basic comparator can be used as the zero crossing detector provided that V_{ref} is set to zero.

Fig a shows the inverting comparator used as a zero-crossing detector. The output voltage v_0 waveform in fig b shows when and in what direction an input signal v_{in} crosses zero volts. That is, the output v_0 is driven into negative saturation when the input signal v_{in} passes through zero in the positive direction, Conversely, when v_{in} passes through zero in the negative direction, the output v_0 switches and saturates positively.

Schmitt Trigger

Fig 8.4 (a) shows an inverting comparator with positive feedback. This circuit converts an irregular shaped waveform to a square wave or pulse. The circuit is known as the Schmitt trigger or squaring circuit.

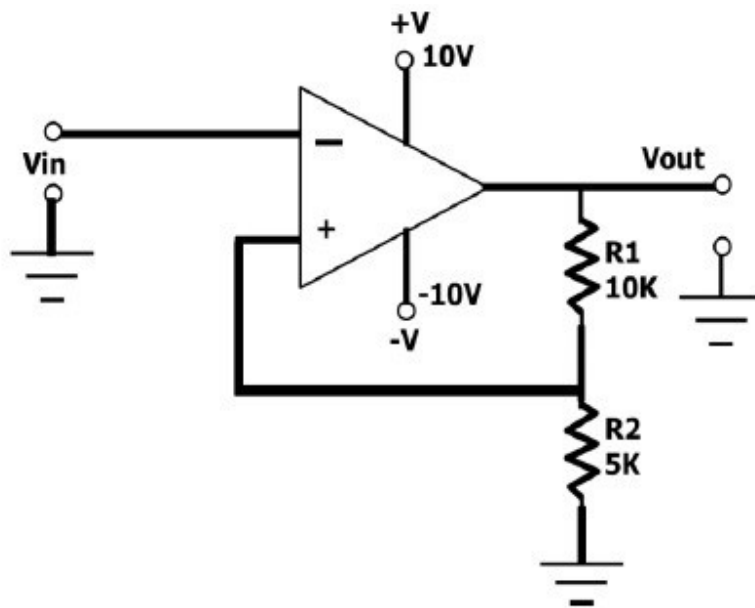

Upper Threshold Voltage

The input voltage v_{in} triggers the output v_o every time it exceeds certain voltage level called the upper threshold voltage V_{ut} and lower threshold voltages that depends on the value and polarity of the output voltage v_o .

When $v_o = +V_{sat}$, the voltage across R_1 is called the upper threshold voltage, V_{ut} . The input voltage v_{in} must be slightly more positive than V_{ut} in order to cause the output v_o to switch from $+V_{sat}$ to $-V_{sat}$. As long as $v_{in} < V_{ut}$, v_o is at $+V_{sat}$. Using the voltage-divider rule,

$$V_{ut} = \frac{R_1}{R_1 + R_2} (+V_{sat})$$

Lower Threshold Voltage

On the other hand, when $v_o = -V_{sat}$, the voltage across R_1 , is referred to as the lower threshold voltage, V_{lt} . v_{in} must be slightly more negative than V_{lt} in order to cause v_o to switch from $-V_{sat}$ to $+V_{sat}$. In other words for v_{in} values greater than V_{lt} , v_o is at $-V_{sat}$. V_{lt} is given by the following equation

$$V_{lt} = \frac{R_1}{R_1 + R_2} (-V_{sat})$$

Hysteresis Characteristics

The comparator with positive feedback is said to exhibit hysteresis, a dead-band condition. That is when the input of the comparator exceeds V_{ut} , its output switches from $+V_{sat}$ to $-V_{sat}$ and reverts back to its original state, $+V_{sat}$, when the input goes below V_{lt} (see figure 8.4c).

The hysteresis voltage is, of course, equal to the difference between V_{ut} and V_{lt} . Therefore

$$\begin{aligned}V_{hy} &= V_{ut} - V_{lt} \\ &= \frac{R_1}{R_1 + R_2} [+V_{sat} - (-V_{at})]\end{aligned}$$